



BERLI[®]
MACCHINE AGRICOLE

TAGLIAERBA

GRASS MOWERS
SICHELMULCHER
TONDEUSES
SEGADORAS



Tagliaerba per trattori da 15 a 120 HP



Grass mowers for tractors from 15 to 120 HP



Sichelmulcher für Traktoren von 15 bis 120 PS



Tondeuses pour tracteurs de 15 à 120 CV





Segadoras para tractores de 15 a 120 CV

BMP-BML









 Serie ad asse verticale con scarico posteriore, per minitrattori di 15-60 HP. Ideale per il taglio dell'erba su parchi, giardini, campi sportivi e aree verdi in genere.





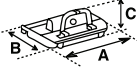

 Vertical-axle finishing mower with rear discharge, to fit tractors of 15-60 HP. Ideal machine for fine cutting of grass in smooth gardens, parks, green areas and sport courts.

 Sichelmäher mit Vertikalachse für Schlepper von 15 bis 60 PS mit Hintenauswurf. Es eignet sich für Parks und Sportplätze

 Tondeuse avec axe vertical à déchargement arrière, pour tracteurs de 15 à 60 CV. Machine idéale pour couper finement l'herbe dans jardins, parcs, espaces verts et terrains de jeu.

 Segadora para la trituración de hierba para parques, jardines, áreas verdes en general para minitractores de 15 a 60 CV.

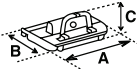
Mod.									
	cm	Min	Max			n°	PTO	A	
BMP 120	120	15	60	3	540	127	123	82	180
BMP 150	150	15	60	3	540	158	132	86	210
BMP 180	180	25	60	3	540	189	132	86	235
BMP 235	235	35	60	3	540	237	123	93	305

Mod.									
	cm	Min	Max			n°	PTO	A	
BML 120	120	15	50	3	540	143	123	82	170
BML 150	150	15	50	3	540	177	132	86	205
BML 180	180	25	50	3	540	214	135	86	230

Per gli accessori vedere pagina nr. 22 - For accessories see on page no. 22 - Für die Zubehör siehe Sie auf Seite Nr. 22
 Pour les accessoires voir page n. 22 - Para los accesorios véase página nr. 22

* Il peso è riferito alla macchina standard (senza accessori) • The weight refers to the machine with standard equipment (without accessories) • Die Gewichtszugebe bezieht sich auf die Maschine in Grundausstattung (ohne Sonderausstattung) • Le poids se réfère à la machine standard (sans accessoires) • El peso se refiere al estándar de la máquina (sin accesorios).



- Attacco terzo punto oscillante.
- Swinging top link.
- Schwenkbar Oberlenk.
- Attelage troisième point oscillant.
- Enganche flotante a los 3 puntos.

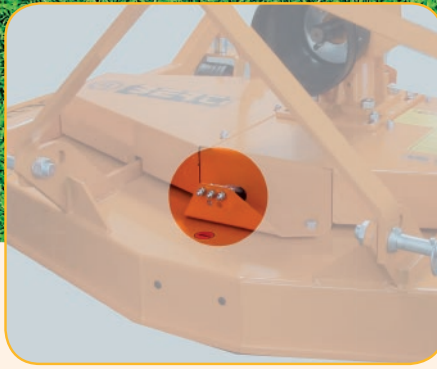

- Lubrificazione centralizzata.
- Central lubrication system.
- Zentralschmierung.
- Point de lubrification centralisée.
- Lubricación centralizada.



- Ruote in gomma piena Ø 210.
- Rubber tires Ø 210.
- Räder aus Gummi Ø 210.
- Roues en caoutchouc plein Ø 210.
- Ruedas de goma Ø 210.



- Coltelli fissi.
- Fixed blades.
- Feste Messern.
- Couteaux fixes.
- Cuchillas fijas.



- Scarico posteriore (BMP).
- Rear discharge (BMP).
- Hinterauswurf (BMP).
- Déchargement postérieur du matériel broyé (BMP).
- Descarga trasera (BMP).

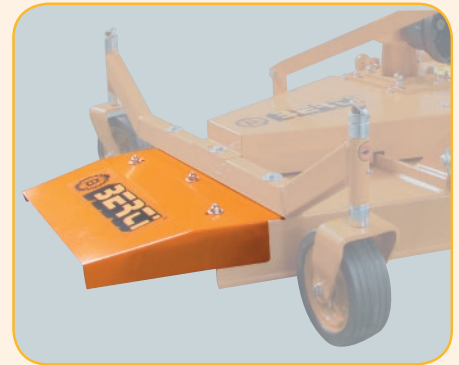

- Scarico laterale (BML).
- Lateral discharge (BML).
- Seitenauswurf (BML).
- Déchargement latéral du matériel broyé (BML).
- Descarga lateral (BML).

OPTIONALS



- Trasmissione 1000 g/min. o 2000 g/min., oraria / antioraria.
- 1000 rpm gearbox or 2000 rpm gearbox, clockwise or anticlockwise.
- Durchantrieb 1000 U/min oder 2000 U/min, rechts bzw. Links.
- Transmission 1000 t/min ou transmission 2000 t/min côté gauche ou droite.
- Transmisión 1000 r/min o 2000 r/min, horaria/antihoraria.



- Ruote pneumatiche Ø 33 cm con portaruote.
- Set pneumatic tires Ø 33 cm with supports.
- Pneumatische Räder Ø 33 cm.
- Jeu roues pneumatiques Ø 33 cm avec supports.
- Ruedas neumáticas Ø 33 cm.





- Kit Mulching.
- Mulching kit.
- Satz "Mulching".
- Double coupe gazon.
- Kit Mulching.





- Albero cardanico con o senza con ruota libera.
- Pto drive shaft with or without free wheel.
- Gelenkwelle mit oder ohne Freilauf.
- Arbre cardan avec ou sans roue libre.
- Cardan con o sin rueda libre.



 Serie ad asse verticale con scarico posteriore, per minitrattori di 15-60 HP. Ideale per il taglio dell'erba su parchi, giardini, campi sportivi, aree verdi in genere e su frutteti.







 Tondeuse avec axe vertical à déchargement arrière, pour tracteurs de 15 à 60 CV. Machine idéale pour couper finement l'herbe dans jardins, parcs, espaces verts et terrains.

 Vertical-axle grass mower with rear discharge, to fit tractors of 15-60 HP. Ideal machine for fine cutting of grass in smooth gardens, parks, green areas, sport courts and orchards.

 Segadora para la trituración de hierba para parques, jardines, áreas verdes en general para minitractores de 15 a 60 CV.

 Sichelmäher mit Vertikalachse für Schlepper von 15 bis 60 PS mit Hintenauswurf. Es eignet sich für Parks und Sportplätzen und Oberbau.

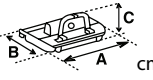
* Il peso è riferito alla macchina standard (senza accessori) • The weight refers to the machine with standard equipment (without accessories) • Die Gewichtszahl bezieht sich auf die Maschine in Grundausstattung (ohne Sonderausstattung) • Le poids se réfère à la machine standard (sans accessoires) • El peso se refiere al estándar de la máquina (sin accesorios).

Mod.									
	cm	Min	Max	n°	PTO	A	B	C	Kg
BMG 100	100	15	60	2	540	118	112	95	120
BMG 120	120	20	60	2	540	131	132	95	175
BMG 150	150	25	60	2	540	162	162	95	225
BMG 180	180	30	60	3	540	192	192	97	350



- Attacco ai tre punti fisso.
- Fixed 3-point linkage.
- Fester Dreipunktbock.
- Attelage fixe à 3 points.
- Enganche fijo a los 3 puntos.



- Slitte di appoggio reversibili e regolabili in altezza.
- Reversible and height adjustable skids.
- Einstellbare und wendbare Kufen.
- Patins réglables en hauteur et réversibles.
- Patines reversibles y regulables en altura.

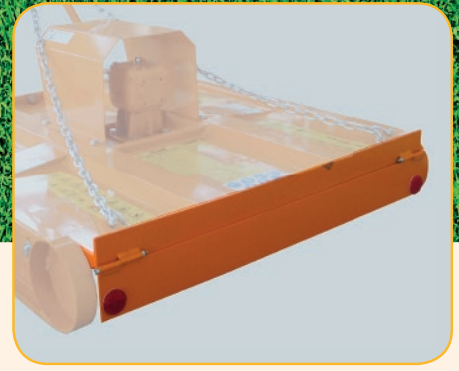

- Scarico posteriore.
- Rear discharge.
- Hinterauswurf.
- Déchargement postérieur du matériel broyé.
- Descarga trasera.



- Coltelli snodati.
- Swinging blades.
- Gelenk- Messer.
- Couteaux articulés.
- Cuchillas articuladas.

OPTIONALS





- Albero cardanico
- Pto drive shaft.
- Gelenkwelle.
- Arbre cardan.
- Cardan.



- 

Falciatrice fissa o spostabile per erba, di tipo portato per l'impiego agricolo su vigneti e frutteti in genere, da applicare su trattori con potenza compresa tra 40 e 120 HP.
- 







Tondeuse fixe ou déportable, indiqué pour broyer l'herbe dans des vignobles et des vergers, à monter sur tracteurs avec puissance entre 40 et 120 CV.
- 

Fixed or displaceable grass mower, suited to work on vineyards and orchards, for tractors from 40 to 120 HP.
- 

Segadora fija o móvil, para la trituración de hierba y uso agrícola en general en viñedos y frutales para tractores de 40 a 120 CV.
- 

Feste oder verschiebbar Sichelmulcher für Gras auf Weinund Obstbau. Für Traktoren von 40 und 120 PS.

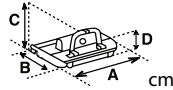
* Il peso è riferito alla macchina standard (senza accessori) • The weight refers to the machine with standard equipment (without accessories) • Die Gewichtszugebe bezieht sich auf die Maschine in Grundausstattung (ohne Sonderausstattung) • Le poids se réfère à la machine standard (sans accessoires) • El peso se refiere al estándar de la máquina (sin accesorios).

Mod.											
	I ↔ I	Min	Max	n°	n°	PTO	A	B	C	D	Kg
STAR 110	116	40	80	2	4	540 (1000)	116	112	93	17	360
STAR 120	120	40	80	2	4	540 (1000)	122	117	93	17	365
STAR 140	140	40	80	2	4	540 (1000)	142	126	96	17	380
STAR 150	150	40	80	2	4	540 (1000)	152	131	96	17	390
STAR 160	161	40	80	2	4	540 (1000)	163	136	96	17	405
STAR 180	182	40	80	2	4	540 (1000)	183	148	94	17	420
STAR 200	200	40	80	2	4	540 (1000)	202	150	94	17	435
STAR 220	220	40	80	2	4	540 (1000)	222	164	94	17	450
STAR 240	241	40	80	2	4	540 (1000)	243	166	94	17	470
STAR 250	250	40	80	2	4	540 (1000)	252	172	94	17	490
STAR 280	280	40	120	2	4	540 (1000)	282	182	94	17	530



- Attacco 3 punti con tirante, Cat. I-II.
- 3-point linkage with top link tie rod, Cat. I-II.
- Dreipunktbock mit Zugstange, Kat. I-II.
- Attelage à 3 points avec tige de renfort, Cat. I-II.
- Eganche a los 3 puntos del tractor con tirante de refuerzo, Cat. I-II.

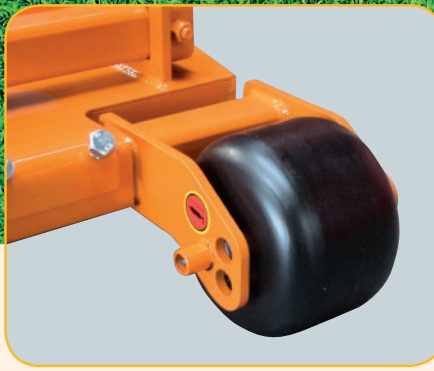

- Ruote frontali, regolabili in altezza e larghezza.
- Front wheels, height and width adjustable.
- Laufräder, Höhen- und Breitenverstellung.
- Roues avants, réglables en hauteur et largeur.
- Ruedas delanteras regulables en altura y anchura.



- Rullo posteriore regolabile in altezza.
- Height adjustable roller.
- Höhenverstellbare Stützwalze.
- Rouleau palpeur réglable en hauteur.
- Rodillo trasero regulable en altura.

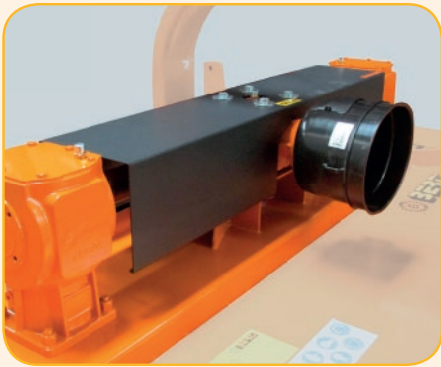

- Trasmissione contro-rotante con tre scatole ingranaggi.
- Counter-rotating transmission, by means of 3 gearboxes.
- Gegenläufiger Getriebeantrieb der Messerrotoren.
- Transmission contre-rotant, à 3 boîtiers.
- Transmisión contra-rotante con 3 cajas de transmisión.

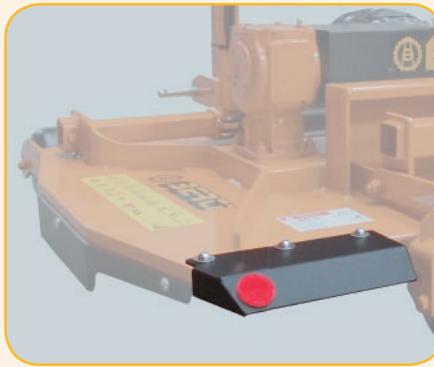

- Scarico posteriore dell'erba.
- Rear side chutes for grass discharge.
- Grasauswurfklappen beidseitig.
- Ailettes pour déchargement arrière de l'herbe.
- Rampas trasera de descarga de la hierba.



- Coltelli snodati.
- Articulated blades.
- Bewegliche Messer.
- Couteaux mobiles.
- Cuchillas articuladas.





- Albero cardanico con frizione e ruota libera.
- PTO drive shaft with clutch and free wheel.
- Gelenkwelle mit Kupplung und Freilauf.
- Arbre cardan avec friction et roue libre.
- Cardan con fricción y rueda libre.

FRUTTI



 Falciatrice spostabile, con telaio ultra piatto, per erba, per l'impiego agricolo su vigneti e frutteti in genere, da applicare su trattori con potenza compresa tra 40 e 80 HP.













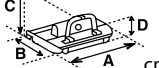

 Displaceable grass mower, with extra flat design, suited to work on vineyards and orchards; for tractors from 40 to 80 HP.

 Verschiebbar Sichelmulcher, extra flach, für Gras auf Wein- und Obstbau. Für Traktoren von 40 und 80 PS.

 Tondeuse déportable pour broyer l'herbe dans des vignobles et des vergers, à monter sur tracteurs avec puissance entre 40 et 80 CV.

 Segadora móvil, para la trituración de hierba y uso agrícola en general en viñedos y frutales para tractores de 40 a 80 CV.

* Il peso è riferito alla macchina standard (senza accessori) • The weight refers to the machine with standard equipment (without accessories) • Die Gewichtszugehörigkeit bezieht sich auf die Maschine in Grundausstattung (ohne Sonderausstattung) • Le poids se réfère à la machine standard (sans accessoires) • El peso se refiere al estándar de la máquina (sin accesorios).

Mod.								
	I ↔ I cm	HP Min Max		n°	n°	PTO	A B C D cm	Kg
FRUTTI 125	121	40 80		2	4	540 (1000)	126 137 98 24	250
FRUTTI 140	136	40 80		2	4	540 (1000)	141 137 98 24	280
FRUTTI 160	157	40 80		2	4	540 (1000)	161 151 98 24	310
FRUTTI 185	179	40 80		3	6	540 (1000)	184 135 98 24	340
FRUTTI 205	202	40 80		3	6	540 (1000)	207 143 98 24	370
FRUTTI 230	233	40 80		3	6	540 (1000)	237 151 98 24	390

Per gli accessori vedere pagina nr. 22 - For accessories see at page no. 22 - Für die Zubehör siehe Sie auf Seite Nr. 22
 Pour les accessoires voir page n. 22 - Para los accesorios véase página nr. 22



- Attacco ai tre punti reversibile (Cat. I) con spostamento idraulico a parallelogramma.
- Reversible double three points linkage (Cat. I) with hydraulic side-shift by parallelogram.
- Umkehrbarer Dreipunktbock (Kat. I) mit hydraulischer Parallelogramm Verschiebung.
- Attelage réversible à 3 points (Cat. I) avec déport hydraulique à parallélogramme.
- Enganche a los 3 puntos reversible (Cat.I) con desplazamiento hidráulico a paralelogramo.

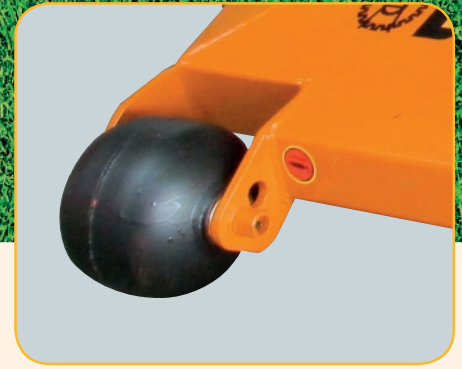

- Ruote fisse frontali, regolabili in altezza.
- Front fixed wheels, height adjustable.
- Laufräder fixe, Höhenverstellung.
- Roues avants fixes, réglables en hauteur.
- Ruedas delanteras fijas regulables en altura.

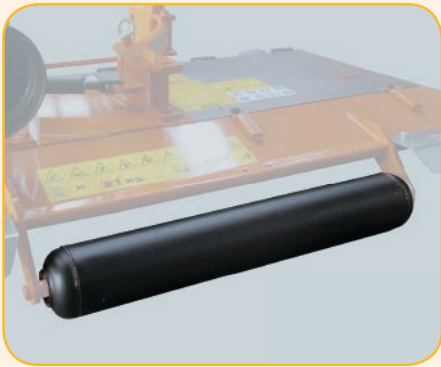

- Rullo posteriore regolabile in altezza.
- Height adjustable roller.
- Höhenverstellbare Stützwalze.
- Rouleau palpeur réglable en hauteur.
- Rodillo trasero regulable en altura.



- Scatola ingranaggi con albero passante.
- Gearbox with through shaft.
- Getriebe mit Durchtrieb.
- Boîtier avec arbre de sortie arrière.
- Caja de transmisión con eje cardan pasante.

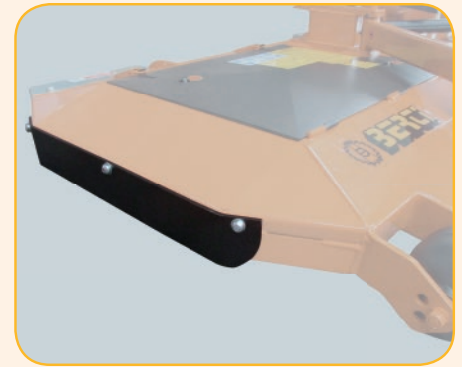

- Sportello laterale apribile.
- Adjustable side chute.
- Auswurfklappen, die geöffnet werden kann.
- Ailette latéral ouvrant.
- Rampa lateral ajustable.



- Scarico posteriore dell'erba.
- Rear side chutes for grass discharge.
- Grasauswurfklappen beidseitig.
- Ailettes pour déchargement arrière de l'herbe.
- Rampas trasera de descarga de la hierba.









- Coltelli snodati.
- Articulated blades.
- Bewegliche Messer.
- Couteaux mobiles.
- Cuchillas articuladas.

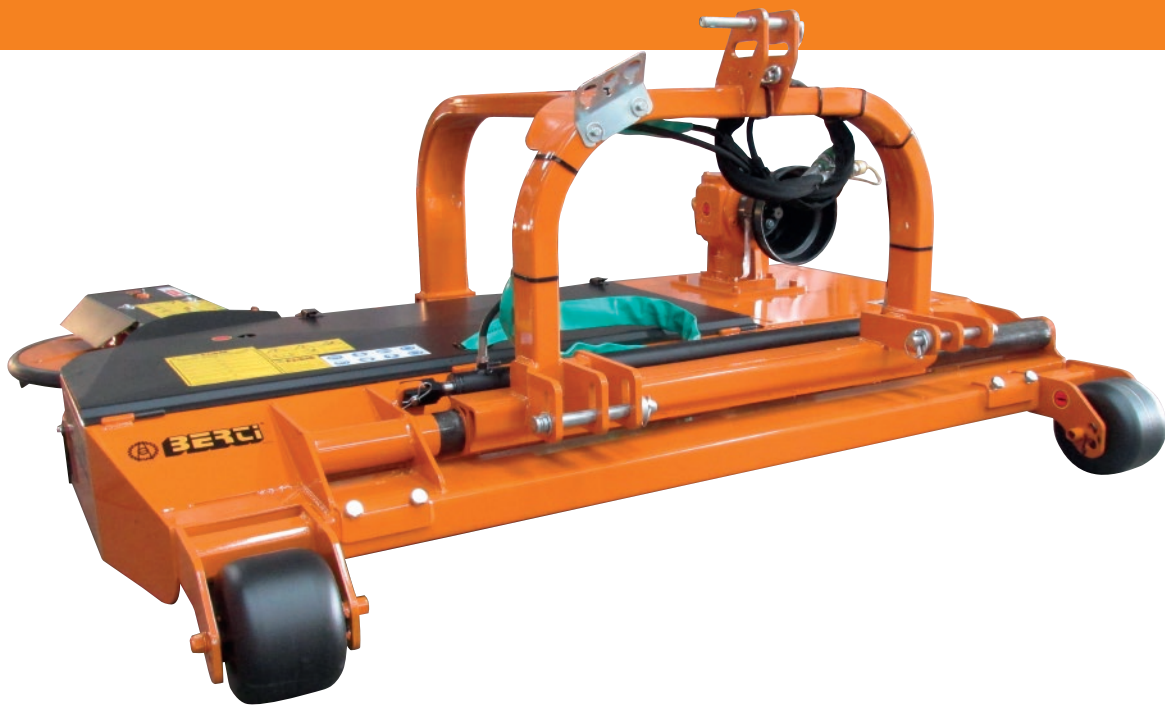









- Albero cardanico con ruota libera.
- PTO drive shaft with free wheel.
- Gelenkwelle mit Freilauf.
- Arbre cardan avec roue libre.
- Cardan con rueda libre.

HANDY

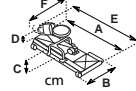

- 
Falciatrice spostabile per erba con disco interfilare, per l'impiego agricolo su vigneti e frutteti in genere, da applicare su trattori con potenza compresa tra 40 e 90 HP.
- 
Tondeuse avec disque entre rangée pivotant, conçue pour broyer l'herbe dans des vignobles et des vergers, à monter sur tracteurs avec puissance entre 40 et 90 CV.
- 
Displaceable grass mower with between-row rotating disc, suited to work on vineyards and orchards; for tractors from 40 to 90 HP.
- 
Segadora móvil, para la trituración de hierba y uso agrícola en general en viñedos y frutales para tractores de 40 a 90 CV.
- 
Verschiebbar Sichelmulcher mit drehbarem Schwenscheibe für Gras auf Wein- und Obstbau. Für Traktoren von 40 und 90 PS.

Mod.	 I ↔ I cm	 HP			 n°	 n°	 PTO							 Kg
		Min	Max					A	B	C	D	E	F	
HANDY 125-170	121-170	40	90	55 71+60 04 130+60	2+1	4+2	540 (1000)	131	148	93	30	178	206	390
HANDY 140-190	147-193	40	90	68 72+60 01 142+60 82 80+60	2+1	4+2	540 (1000)	141	152	93	30	199	210	420
HANDY 160-210	166-214	40	90	12 150+60 91 90+60	2+1	4+2	540 (1000)	172	159	93	30	220	217	450
HANDY 180-230	192-234	40	90	01 180+60 90 111+60	3+1	6+2	540 (1000)	198	148	93	30	239	204	490
HANDY 200-250	209-254	40	90	0 201+60 96 138+60	3+1	6+2	540 (1000)	215	123	93	30	260	210	520
HANDY 230-280	239-287	40	90	06 228+60 96 153+60	3+1	6+2	540 (1000)	245	159	93	30	293	217	550
HANDY 250-300	252-302	40	90	06 243+60 135 130+60	3+1	6+2	540 (1000)	258	163	93	30	309	221	580
HANDY 270-320	273-318	40	90	45 220+60 158 152+60	4+1	8+2	540 (1000)	279	152	93	30	324	210	600
HANDY 310-360	314-363	40	90	68 242+60 182 187+60	4+1	8+2	540 (1000)	320	159	93	30	369	217	660
HANDY 360-410	361-415	40	90	92 277+60	4+1	8+2	540 (1000)	368	173	93	30	423	234	750

Per gli accessori vedere pagina nr. 22 - For accessories see at page no. 22 - Für die Zubehör siehe Sie auf Seite Nr. 22
 Pour les accessoires voir page n. 22 - Para los accesorios véase página nr. 22

* Il peso è riferito alla macchina standard (senza accessori) • The weight refers to the machine with standard equipment (without accessories) • Die Gewichtszahl bezieht sich auf die Maschine in Grundausstattung (ohne Sonderausstattung) • Le poids se réfère à la machine standard (sans accessoires) • El peso se refiere al estándar de la máquina (sin accesorios).

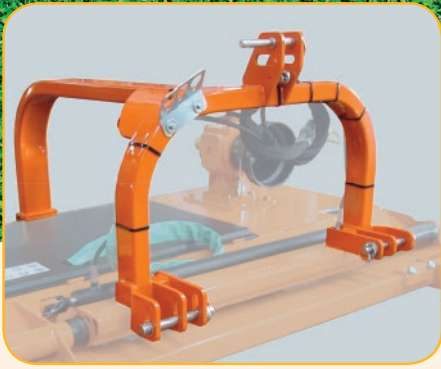

- Attacco a tre punti spostabile idraulicamente, Cat. I-II.
- Displaceable 3-point linkage, Cat. I-II.
- Umkehrbarer Dreipunktbock, Kat. I-II.
- Attelage déportable à 3 points, Cat. I-II.
- Enganche a los 3 puntos, Cat. I-II.



- Ruote fisse frontali, regolabili in altezza.
- Front fixed wheels, height adjustable.
- Laufräder fixe, Höhenverstellung.
- Roues avants fixes, réglables en hauteur.
- Ruedas delanteras fijas regulables en altura.

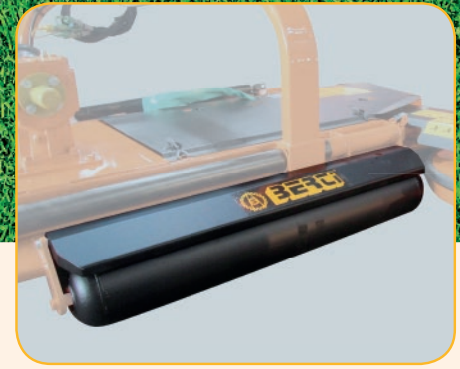

- Rullo posteriore regolabile in altezza.
- Height adjustable roller.
- Höhenverstellbare Stützwalze.
- Rouleau palpeur réglable en hauteur.
- Rodillo trasero regulable en altura.

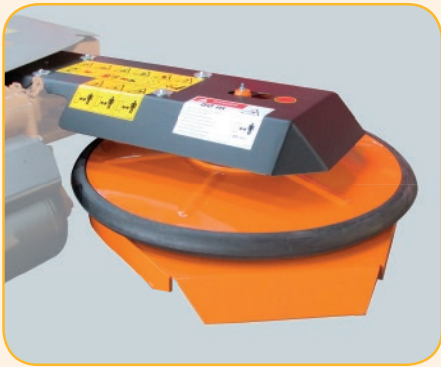

- Disco interfilare girevole Ø 60 cm, con rientro a molla e protezione in gomma.
- Between-row rotating disc Ø 60 cm, by means of spring, with rubber protection.
- Drehbare Schwenkscheibe Ø 60 cm mit Federzug.
- Disque entre rangée pivotant Ø 60 cm avec rentrée par ressort et protection en caoutchouc.
- Disco entre-hileras Ø 60 cm con protección de goma y sistema de accionamiento por resorte.



- Coltelli snodati.
- Articulated blades.
- Bewegliche Messer.
- Cousteaux mobiles.
- Cuchillas articuladas.



- Albero cardanico.
- PTO drive shaft.
- Gelenkwelle.
- Arbre cardan.
- Cardan.

FLEXY



Falciatrice a larghezza variabile per erba, di tipo portato per l'impiego agricolo su vigneti e frutteti in genere, da applicare su trattori con potenza compresa tra 40 e 100 HP.



Grass mower with variable working width, suited to work on vineyards and orchards; for tractors from 40 to 100 HP.









Sichelmulcher mit variabler Arbeitsbreite für Gras auf Wein- und Obstbau. Für Traktoren von 40 und 100 PS.



Tondeuse avec largeur de travail variable, conçue pour broyer l'herbedans des vignobles et des vergers, à monter sur tracteurs avec puissance entre 40 et 100 CV.

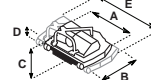

Segadora de corte variable, para la trituración de hierba y uso agrícola en general en viñedos y frutales para tractores de 40 a 100 CV.

Mod.												
		Min	Max				n°	n°	PTO	A	B	
FLEXY 110-145	109-141	40	100	2	4	540 (1000)	112	129	107	24	144	430
FLEXY 125-175	126-170	40	100	2	4	540 (1000)	130	139	107	24	174	470
FLEXY 140-195	137-193	40	100	2	4	540 (1000)	141	149	107	24	197	510
FLEXY 160-230	162-223	40	100	2	4	540 (1000)	165	170	101	22	226	580
FLEXY 170-245	173-243	40	100	2	4	540 (1000)	178	165	101	22	248	540
FLEXY 190-260	189-259	40	100	2	4	540 (1000)	192	189	101	22	262	690
FLEXY 220-300	220-299	40	100	2	4	540 (1000)	223	210	101	22	203	790

Per gli accessori vedere pagina nr. 22 - For accessories see at page no. 22 - Für die Zubehör siehe Sie auf Seite Nr. 22
 Pour les accessoires voir page n. 22 - Para los accesorios véase página nr. 22

* Il peso è riferito alla macchina standard (senza accessori) • The weight refers to the machine with standard equipment (without accessories) • Die Gewichtszugebe bezieht sich auf die Maschine in Grundausstattung (ohne Sonderausstattung) • Le poids se réfère à la machine standard (sans accessoires) • El peso se refiere al estándar de la máquina (sin accesorios).

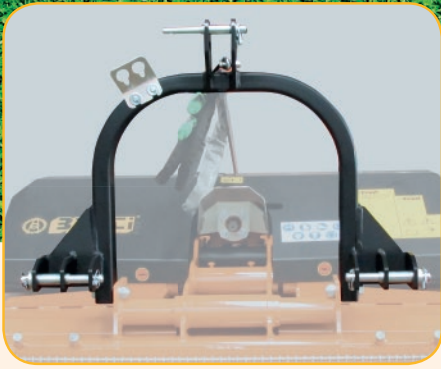

- Attacco ai tre punti fisso, Cat. I-II.
- Fixed 3-point linkage, Cat. I-II.
- Fester Dreipunktbock, Kat. I-II.
- Attelage fixe à 3 points, Cat. I-II.
- Enganche fijo a los 3 puntos, Cat. I-II.



- Larghezza di lavoro variabile.
- Adjustable working width.
- Verstellbare Arbeitsbreite.
- Largeur de travail réglable.
- Anchura de trabajo regulable.

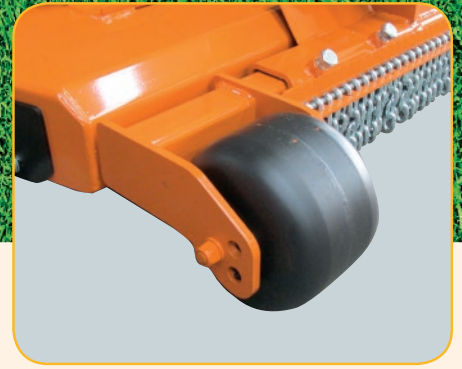

- Ruote frontali, regolabili in altezza e larghezza*
- Front wheels, height and width adjustable*
- Laufräder, Höhen- und Breitenverstellung*
- Roues avants, réglables en hauteur et largeur*
- Ruedas delanteras regulables en altura y anchura*
*(no 110-145 / 170-245).

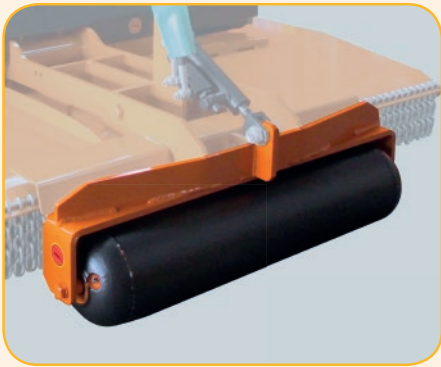

- Rullo posteriore regolabile in altezza.
- Height adjustable roller.
- Höhenverstellbare Stützwalze.
- Rouleau palpeur réglable en hauteur.
- Rodillo trasero regulable en altura.



- Sportelli laterali per scarico dell'erba (>125)*.
- Side chutes for grass discharge (>125)*.
- Grasauswurfklappen beidseitig (>125)*.
- Ailettes pour déchargement latéral de l'herbe (>125)*.
- Rampas laterales de descarga de la hierba (>125)*.
*(no 170-245)

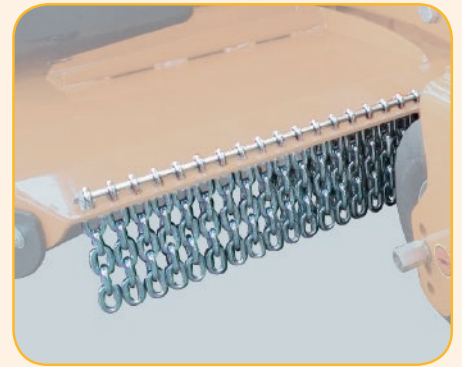

- Protezioni in catena frontali e posteriori.
- Chain guards, front and rear.
- Kettenschützen vorne und hinten.
- Chaînes de protections avants et arrière.
- Protección en cadenas delanteras y traseras.



- Coltelli snodati.
- Articulated blades.
- Bewegliche Messer.
- Couteaux mobiles.
- Cuchillas articuladas.



- Albero cardanico con frizione e ruota libera*.
- PTO drive shaft with clutch and free wheel*.
- Gelenkwelle mit Kupplung und Freilauf*.
- Arbre cardan avec friction et roue libre*.
- Cardan con embrague y rueda libre*.
- * (Mod. 110-145 solo con ruota libera / only with free wheel
nur mit Freilauf / seulement avec roue libre / solo con rueda libre)

FLEXY/T



Falciatrice automatica a larghezza variabile per erba, di tipo portato per l'impiego agricolo su vigneti e frutteti in genere, da applicare su trattori con potenza compresa tra 40 e 100 HP.



Grass mower with variable working width (automatic device), suited to work on vineyards and orchards. for tractors from 40 to 100 HP.



Sichelmulcher mit variabler Arbeitsbreite (Automatisch Taster-Vorrichtung) für Gras auf Wein- und Obstbau. Für Traktoren von 40 und 100 PS.



Tondeuse avec largeur de travail variable automatiquement, conçue pour broyer l'herbedans des vignobles et des vergers, à monter sur tracteurs avec puissance entre 40 et 100 CV.



Segadora automática de corte variable para el trabajo en viñedos y explotaciones hortofrutícolas. Para tractores de 40 a 100 C.V. de potencia.

Mod.						PTO						
		cm	Min				Max	n°	n°	A	B	
FLEXY 110-145	109-141	40	100	2	4	540 (1000)	112	129	107	24	144	480
FLEXY 125-175	126-170	40	100	2	4	540 (1000)	130	139	107	24	174	520
FLEXY 140-195	137-193	40	100	2	4	540 (1000)	141	149	107	24	197	560
FLEXY 160-230	162-223	40	100	2	4	540 (1000)	165	170	101	22	226	630
FLEXY 170-245	173-243	40	100	2	4	540 (1000)	178	165	101	22	248	590
FLEXY 190-260	189-259	40	100	2	4	540 (1000)	192	189	101	22	262	740
FLEXY 220-300	220-299	40	100	2	4	540 (1000)	223	210	101	22	203	840

Per gli accessori vedere pagina nr. 22 - For accessories see at page no. 22 - Für die Zubehör siehe Sie auf Seite Nr. 22
 Pour les accessoires voir page n. 22 - Para los accesorios véase página nr. 22

* Il peso è riferito alla macchina standard (senza accessori) • The weight refers to the machine with standard equipment (without accessories) • Die Gewichtszugebe bezieht sich auf die Maschine in Grundausstattung (ohne Sonderausstattung) • Le poids se réfère à la machine standard (sans accessoires) • El peso se refiere al estándar de la máquina (sin accesorios).

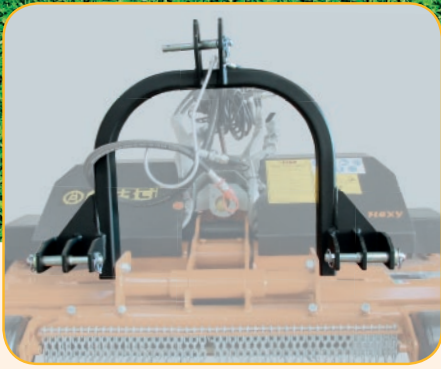

- Attacco ai tre punti fisso, Cat. I-II.
- Fixed 3-point linkage, Cat. I-II.
- Fester Dreipunktbock, Kat. I-II.
- Attelage fixe à 3 points, Cat. I-II.
- Enganche fijo a los 3 puntos, Cat. I-II.

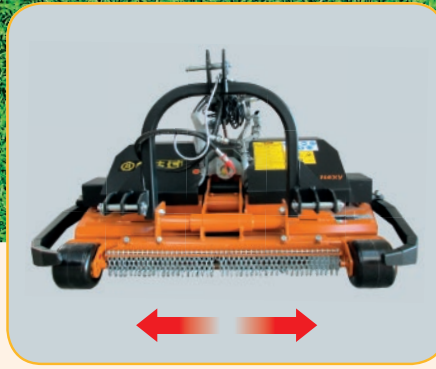

- Larghezza di lavoro variabile.
- Adjustable working width.
- Verstellbare Arbeitsbreite.
- Largeur de travail réglable.
- Anchura de trabajo regulable.



- Tastatori idraulici bilaterali.
- Hydraulic automatic precision sensors both side.
- Hydraulische Feintastautomatik beidseitig.
- Tâteurs hydrauliques bilatérales.
- Palpador hidráulico a ambos lados.

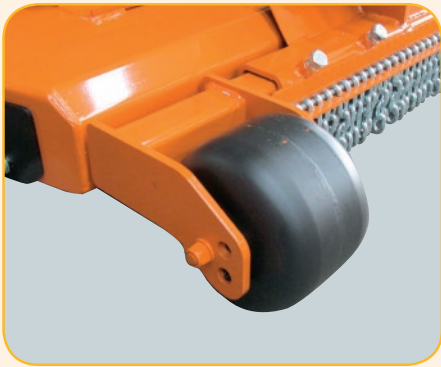

- Ruote frontali, regolabili in altezza e larghezza*.
- Front wheels, height and width adjustable*.
- Laufräder, Höhen- und Breitenverstellung*.
- Roues avants, réglables en hauteur et largeur*.
- Ruedas delanteras regulables en altura y anchura*.

*(no 110-145 / 170-245)

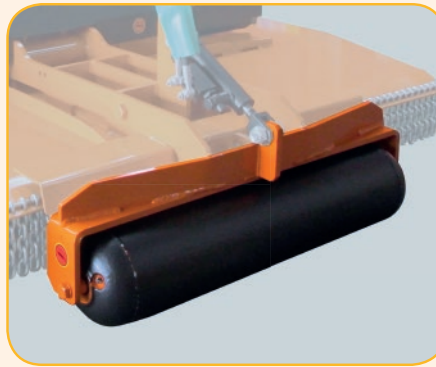

- Rullo posteriore regolabile in altezza.
- Height adjustable roller.
- Höhenverstellbare Stützwalze.
- Rouleau palpeur réglable en hauteur.
- Rodillo trasero regulable en altura.



- Sportelli laterali per scarico dell'erba (>125)*.
- Side chutes for grass discharge (>125)*.
- Grasauswurfklappen beidseitig (>125)*.
- Ailettes pour déchargement latéral de l'herbe (>125)*.
- Rampas laterales de descarga de la hierba (>125)*.

*(no 170-245).

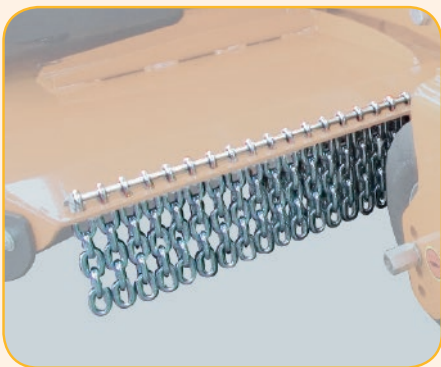

- Protezioni in catena frontali e posteriori.
- Chain guards, front and rear.
- Kettenschützen vorne und hinten.
- Chaînes de protections avants et arrière.
- Protección en cadenas delanteras y traseras.



- Coltelli snodati.
- Articulated blades.
- Bewegliche Messer.
- Couteaux mobiles.
- Cuchillas articuladas.



- Albero cardanico con frizione e ruota libera*.
- PTO drive shaft with clutch and free wheel*.
- Gelenkwelle mit Kupplung und Freilauf*.
- Arbre cardan avec friction et roue libre*.
- Cardan con embrague y rueda libre*.

*(Mod. 110-145 solo con ruota libera only with free wheel / nur mit Freilauf seulement avec roue libre / solo con rueda libre)

VARY/W



- Falciatrice a larghezza variabile per erba, di tipo portato per l'impiego agricolo su vigneti e frutteti in genere, da applicare su trattori con potenza compresa tra 30 e 120 HP.
- Tondeuse avec largeur de travail variable pour broyer l'herbe dans des vignobles et des vergers, à monter sur tracteurs avec puissance entre 30 et 120 CV.
- Grass mower of variable width, suited to work on vineyards and orchards; for tractors from 30 to 120 HP.
- Segadora automática de corte variable para la hierba y el trabajo en viñedos y explotaciones hortofrutícolas en general. Para tractores de 30 a 120 C.V. de potencia.
- Sichelmulcher mit variabler Arbeitsbreite für Gras auf Wein- und Obstbau. Für Traktoren von 30 und 120 PS.

* Il peso è riferito alla macchina standard (senza accessori) • The weight refers to the machine with standard equipment (without accessories) • Die Gewichtszugebe bezieht sich auf die Maschine in Grundausstattung (ohne Sonderausstattung) • El peso se refiere al estándar de la máquina (sin accesorios).

Mod.													
	A	B	Min	Max					n°	n°	PTO	A	B
VARY/W 110-190 Ø 45	116	190	30	80	4	8	540 (1000)	121	162	94	25	195	380
VARY/W 120-200 Ø 45	121	202	30	80	4	8	540 (1000)	126	144	94	25	207	430
VARY/W 130-210 Ø 45	130	213	30	80	4	8	540 (1000)	135	149	94	25	218	490
VARY/W 140-220 Ø 45	138	223	30	80	4	8	540 (1000)	143	154	94	25	228	530
VARY/W 140-245 Ø 60	155	253	30	80	4	8	540 (1000)	164	173	94	25	262	540
VARY/W 160-265 Ø 60	159	266	30	80	4	8	540 (1000)	165	178	94	25	275	560
VARY/W 180-285 Ø 60	176	286	40	80	4	8	540 (1000)	183	185	94	25	294	590
VARY/W 200-305 Ø 60	200	307	50	80	4	8	540 (1000)	204	196	94	25	315	630
VARY/W 220-325 Ø 60	217	326	50	80	4	8	540 (1000)	223	211	94	25	335	670
VARY/W 240-345 Ø 60	239	347	60	120	4	8	540 (1000)	245	221	94	25	356	700

Per gli accessori vedere pagina nr. 22 - For accessories see at page no. 22 - Für die Zubehör siehe Sie auf Seite Nr. 22
 Pour les accessoires voir page n. 22 - Para los accesorios véase página nr. 22



- Attacco ai tre punti fisso, Cat. I-II.
- Fixed 3-point linkage, Cat. I-II.
- Fester Dreipunktbock, Kat. I-II.
- Attelage fixe à 3 points, Cat. I-II.
- Enganche fijo a los 3 puntos, Cat. I-II.



- Ruote frontali, regolabili in altezza e larghezza.
- Front wheels, height and width adjustable.
- Laufräder, Höhen- und Breitenverstellung.
- Roues avants, réglables en hauteur et largeur.
- Ruedas delanteras regulables en altura y anchura.



- Rullo posteriore regolabile in altezza.
- Height adjustable roller.
- Höhenverstellbare Stützwalze.
- Rouleau palpeur réglable en hauteur.
- Rodillo trasero regulable en altura.

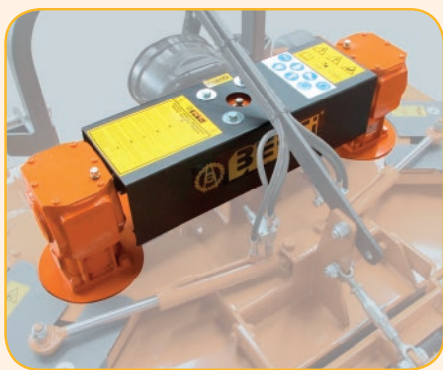

- Trasmissione contro-rotante con tre scatole ingranaggi.
- Counter-rotating transmission, by means of 3 gearboxes.
- Gegenläufiger Getriebeantrieb der Messerrotoren.
- Transmission contre-rotant, à 3 boîtiers.
- Transmisión contra-rotante con 3 cajas de transmisión.

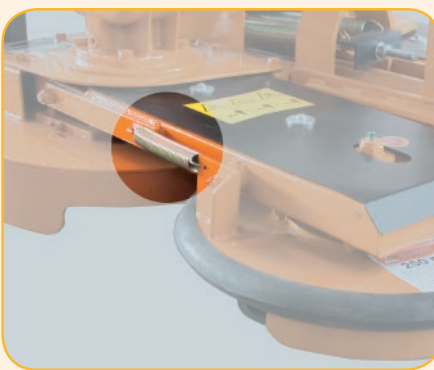

- Trasmissione a cinghie dei dischi laterali con rientro a molla dei dischi.
- Belts transmission on the lateral discs with between-row device by means of springs.
- Schwenkscheiben mit Keilriemenantrieb mit Federzug.
- Transmission par courroies sur les disques latéraux avec rentrée par ressort des disques.
- Transmisión a correas de los discos laterales interfilas con sistema de protección accionado por resortes.



- Apertura/chiusura idraulica dei bracci.
- Hydraulic adjustable arms.
- Hydraulische verstellbare Schwenkarme.
- Ouverture et fermeture hydraulique des bras.
- Anchura/cierre hidráulica de los brazos.









- Coltelli snodati.
- Articulated blades.
- Bewegliche Messer.
- Couteaux mobiles.
- Cuchillas articuladas.

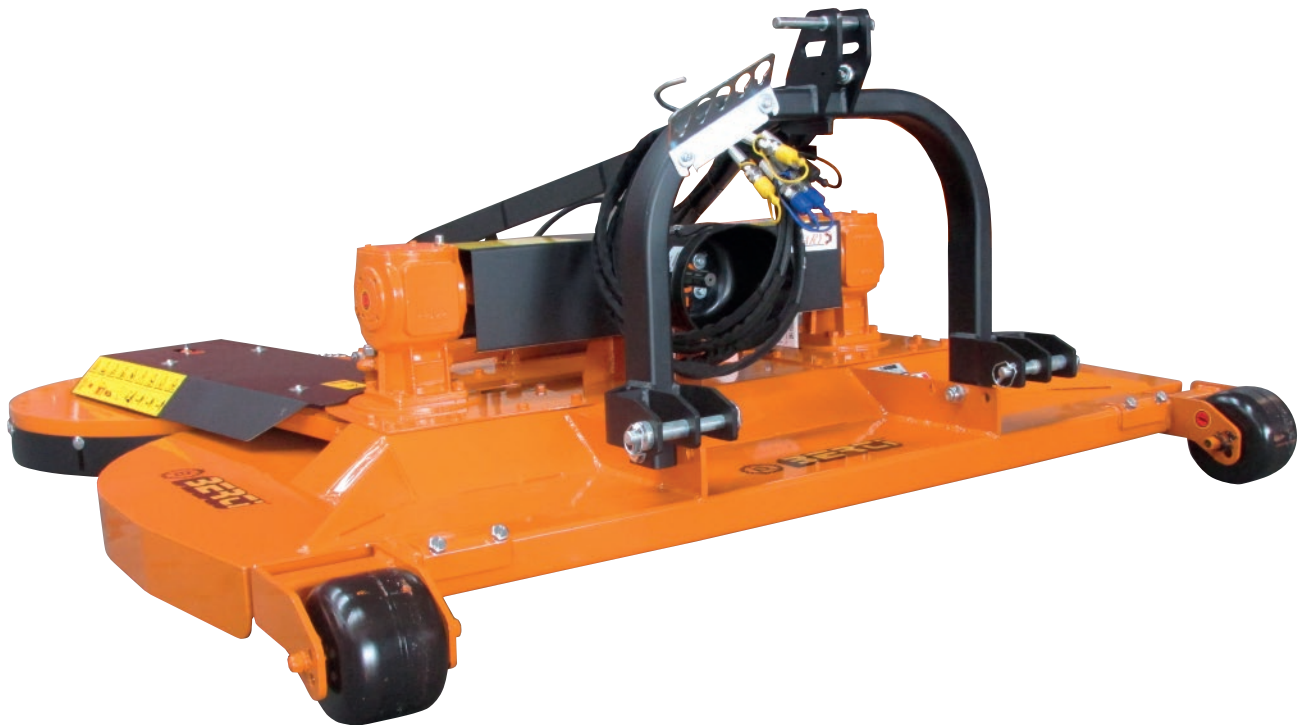







- Albero cardanico con frizione e ruota libera.
- PTO drive shaft with clutch and free wheel.
- Gelenkwelle mit Kupplung und Freilauf.
- Arbre cardan avec friction et roue libre.
- Cardan con embrague y rueda libre.

VARY

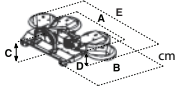

-  Falciatrice a larghezza variabile per erba, di tipo portato per l'impiego agricolo su vigneti e frutteti in genere, da applicare su trattori con potenza compresa tra 30 e 120 HP.
-  Tondeuse avec largeur de travail variable pour broyer l'herbe dans des vignobles et des vergers, à monter sur tracteurs avec puissance entre 30 et 120 CV.
-  Grass mower of variable width, suited to work on vineyards and orchards; for tractors from 30 to 120 HP.
-  Segadora de corte variable, para la trituración de hierba y uso agrícola en general en viñedos y frutales para tractores de 30 a 120 CV.
-  Sichelmulcher mit variabler Arbeitsbreite für Gras auf Wein- und Obstbau. Für Traktoren von 30 und 120 PS.

Mod.													
	A	B	Min	Max				n°	n°	PTO	A	B	
VARY 140-245 Ø 60	146	245	30	80	4	8	540 (1000)	151	168	95	26	250	540
VARY 160-260 Ø 60	165	263	30	80	4	8	540 (1000)	170	173	95	26	268	560
VARY 160-280 Ø 70	171	279	30	80	4	8	540 (1000)	175	181	95	26	283	570
VARY 180-280 Ø 60	178	279	40	80	4	8	540 (1000)	182	183	95	26	284	590
VARY 180-300 Ø 70	180	302	40	80	4	8	540 (1000)	184	193	95	26	307	600
VARY 180-320 Ø 80	185	315	40	80	4	8	540 (1000)	189	201	95	26	321	610
VARY 200-300 Ø 60	198	303	50	80	4	8	540 (1000)	202	190	97	26	308	630
VARY 200-320 Ø 70	201	325	50	80	4	8	540 (1000)	204	198	97	26	330	640
VARY 200-340 Ø 80	198	336	50	80	4	8	540 (1000)	202	211	97	26	234	650
VARY 200-360 Ø 90	204	359	50	80	4	8	540 (1000)	208	222	97	26	365	660
VARY 220-320 Ø 60	217	322	50	80	4	8	540 (1000)	223	203	97	26	327	670
VARY 220-340 Ø 70	217	338	50	80	4	8	540 (1000)	223	211	97	26	343	680
VARY 220-360 Ø 80	219	363	50	80	4	8	540 (1000)	225	222	97	26	368	690
VARY 220-380 Ø 90	224	379	50	80	4	8	540 (1000)	229	231	97	26	384	700
VARY 240-400 Ø 90	241	400	60	120	4	8	540 (1000)	244	241	97	26	405	720
VARY 290-450 Ø 90	291	448	60	120	5	10	540 (1000)	296	223	98	31	454	850
VARY 330-490 Ø 90	326	484	60	120	5	10	540 (1000)	333	232	98	31	489	980
VARY 360-520 Ø 90	359	518	60	120	5	10	540 (1000)	365	241	98	31	524	1100

Per gli accessori vedere pagina nr. 22 - For accessories see at page no. 22 - Für die Zubehör siehe Sie auf Seite Nr. 22
 Pour les accessoires voir page n. 22 - Para los accesorios véase página nr. 22

* Il peso è riferito alla macchina standard (senza accessori) • The weight refers to the machine with standard equipment (without accessories) • Die Gewichtszahl bezieht sich auf die Maschine in Grundausstattung (ohne Sonderausstattung) • Le poids se réfère à la machine standard (sans accessoires) • El peso se refiere al estándar de la máquina (sin accesorios).



- Attacco ai tre punti fisso, Cat. I-II.
- Fixed 3-point linkage, Cat. I-II.
- Fester Dreipunktbock, Kat. I-II.
- Attelage fixe à 3 points, Cat. I-II.
- Enganche fijo a los 3 puntos, Cat. I-II.



- Ruote frontali, regolabili in altezza e larghezza.
- Front wheels, height and width adjustable.
- Laufräder, Höhen- und Breitenverstellung.
- Roues avants, réglables en hauteur et largeur.
- Ruedas frontales regulables en altura y anchura.



- Rullo posteriore regolabile in altezza.
- Height adjustable roller.
- Höhenverstellbare Stützwalze.
- Rouleau palpeur réglable en hauteur.
- Rodillo trasero regulable en altura.

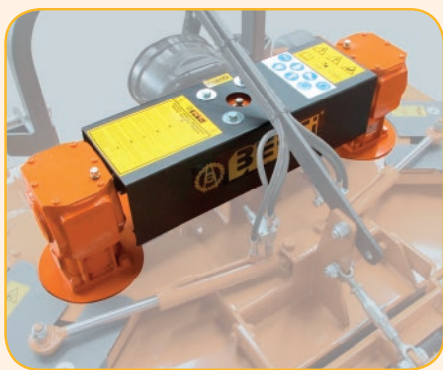

- Trasmissione contro-rotante con tre scatole ingranaggi.
- Counter-rotating transmission, by means of 3 gearboxes.
- Gegenläufiger Getriebeantrieb der Messerrotoren.
- Transmission contre-rotant, à 3 boîtiers.
- Transmisión contra-rotante con 3 cajas de transmisión.



- Trasmissione a cinghie dei dischi laterali.
- Belts transmission on the lateral discs.
- Schwenkscheiben mit Keilriemenantrieb.
- Transmission par courroies sur les disques latéraux.
- Transmisión a correas de los discos laterales interfilas.



- Apertura/chiusura idraulica dei bracci.
- Hydraulic adjustable arms.
- Hydraulische verstellbare Schwenkarme.
- Ouverture et fermeture hydraulique des bras.
- Anchura/cierre hidráulica de los brazos.



- Sportelli laterali per scarico dell'erba sui dischi.
- Side chutes for grass discharge on swing arms and disks.
- Grasauswurfklappen beidseitig an den Schwenkscheiben.
- Ailettes pour déchargement latéral de l'herbe sur les disques.
- Rampas laterales de descarga de la hierba.



- Coltelli snodati.
- Articulated blades.
- Bewegliche Messer.
- Couteaux mobiles.
- Cuchillas articuladas.





- Albero cardanico con frizione e ruota libera.
- PTO drive shaft with clutch and free wheel.
- Gelenkwelle mit Kupplung und Freilauf.
- Arbre cardan avec friction et roue libre.
- Cardan con embrague y rueda libre.

VARY/K



- 

Falciatrice a larghezza variabile snodata centralmente (0°/+15°) per erba, di tipo portato per l'impiego agricolo su vigneti e frutteti in genere, da applicare su trattori con potenza compresa tra 40 e 120 HP.
- 







Tondeuse avec largeur de travail variable et articulation au milieu (0°/+15°) pour broyer l'herbe dans des vignobles et des vergers, à monter sur tracteurs avec puissance entre 40 et 120 CV.
- 

Grass mower of variable width and centre joint device (0°/+15°), suited to work on vineyards and orchards; for tractors from 40 to 120 HP.
- 

Desbrozadora de hierba con anchura de trabajo variable y articulada centralmente (0°/+15°) para el trabajo en viñedos y explotaciones hortofrutícolas. Para tractores de 40 a 120 CV de potencia.
- 

Sichelmulcher mit variabler Arbeitsbreite und mittlerer Gelenk-Vorrichtung (0°/+15°) für Gras auf Wein- und Obstbau. Für Traktoren von 40 und 120 PS.

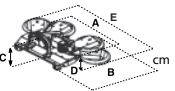
* Il peso è riferito alla macchina standard (senza accessori) • The weight refers to the machine with standard equipment (without accessories) • Die Gewichtszugebe bezieht sich auf die Maschine in Grundausstattung (ohne Sonderausstattung) • Le poids se réfère à la machine standard (sans accessoires) • El peso se refiere al estándar de la máquina (sin accesorios).

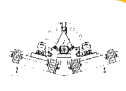
Mod.														
	A	B	Min	Max				A	B	C	D	E		
VARY/K 150-250 Ø 60	149	256	30	80	4	8	540 (1000)	152	176	105	26	253	570	0° - +15°
VARY/K 150-270 Ø 70	154	269	30	80	4	8	540 (1000)	158	192	105	26	273	580	0° - +15°
VARY/K 190-290 Ø 60	185	290	50	80	4	8	540 (1000)	188	195	105	26	294	690	0° - +15°
VARY/K 190-310 Ø 70	200	304	50	80	4	8	540 (1000)	204	200	105	26	308	700	0° - +15°
VARY/K 190-330 Ø 80	185	326	50	80	4	8	540 (1000)	188	218	105	26	330	710	0° - +15°
VARY/K 190-350 Ø 90	189	359	50	80	4	8	540 (1000)	191	216	105	26	353	720	0° - +15°
VARY/K 230-330 Ø 60	225	338	60	120	4	8	540 (1000)	231	243	94	32	342	770	0° - +15°
VARY/K 230-350 Ø 70	225	356	60	120	4	8	540 (1000)	231	352	94	32	359	780	0° - +15°
VARY/K 230-370 Ø 80	225	371	60	120	4	8	540 (1000)	231	260	94	32	376	790	0° - +15°
VARY/K 230-390 Ø 90	229	391	60	120	4	8	540 (1000)	234	271	94	32	396	800	0° - +15°

Per gli accessori vedere pagina nr. 22 - For accessories see at page no. 22 - Für die Zubehör siehe Sie auf Seite Nr. 22
 Pour les accessoires voir page n. 22 - Para los accesorios véase página nr. 22



- Attacco ai tre punti fisso, Cat. I (<190); I-II (>230).
- Fixed 3-point linkage, Cat. I (<190); I-II (>230).
- Fester Dreipunktbock, Kat. I (<190); I-II (>230).
- Attelage fixe à 3 points, Cat. I (<190); I-II (>230).
- Enganche fijo a los 3 puntos, Cat. I (<190); I-II (>230).



- Ruote in gomma fisse frontali, regolabili in altezza e larghezza (>190).
- Front fixed rubber wheels, height and width adjustable (>190).
- Laufräder fixe aus Gummi, Höhen und Breitenverstellung (>190).
- Roues avants fixes en caoutchouc, réglables en hauteur et largeur (>190).
- Ruedas frontales fijas de goma regulables en altura y anchura (>190).



- Ruote in gomma posteriori, regolabile in altezza.
- Rear rubber wheels, height adjustable.
- Laufräder aus Gummi höhenverstellbar.
- Roues arrière en caoutchouc, réglable en hauteur.
- Ruedas traseras de goma regulables en altura.

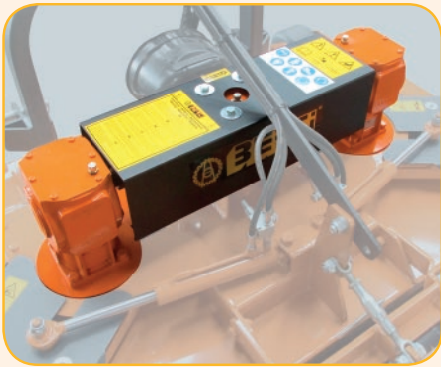

- Trasmissione contro-rotante con tre scatole ingranaggi.
- Counter-rotating transmission, by means of 3 gearboxes.
- Gegenläufiger Getriebeantrieb der Messerrotoren.
- Transmission contre-rotant, à 3 boîtiers.
- Transmisión contra-rotante con 3 cajas de transmisión.



- Trasmissione a cinghie dei dischi laterali.
- Belts transmission on the lateral discs.
- Schwenkscheiben mit Keilriemenantrieb.
- Transmission par courroies sur les disques latéraux.
- Transmisión a correas de los discos laterales interfilas.



- Apertura/chiusura idraulica dei bracci.
- Hydraulic adjustable arms.
- Zwei hydraulische verstellbare Schwenkarme.
- Ouverture et fermeture hydraulique des braspar.
- Anchura/cierre hidráulica de los brazos.



- Sportelli laterali per scarico dell'erba sui dischi.
- Side chutes for grass discharge on swing arms and disks.
- Grasauswurfklappen beidseitig an den Schwenkscheiben.
- Ailettes pour déchargement latéral de l'herbe sur les disques.
- Rampas laterales de descarga de la hierba.



- Coltelli snodati.
- Articulated blades.
- Bewegliche Messer.
- Couteaux mobiles.
- Cuchillas articuladas.



- Albero cardanico con frizione e ruota libera.
- PTO drive shaft with clutch and free wheel.
- Gelenkwelle mit Kupplung und Freilauf.
- Arbre cardan avec friction et roue libre.
- Cardan con embrague y rueda libre.



STAR

OPTIONALS



- Spostamento idraulico.
- Hydraulic side-shift.
- Hydraulische Seitenverschiebung.
- Déport hydraulique.
- Desplazamiento hidráulico.

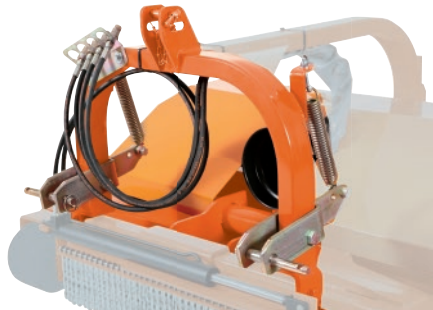

- Ammortizzatore di scarico peso, sul terzo punto (>180).
- Relief device for top link (>180).
- Entlastungsvorrichtung für Oberlenk (>180).
- Système de soutien du troisième point (>180).
- Amortiguador de descarga del peso al tercer punto(>180).



- Ruote in gomma fisse anteriori.
- Two pneumatic fixed rubber wheels, front mounted.
- 2 fixe Gummiräder vorne.
- Roues avants fixes en caoutchouc.
- Ruedas delanteras fijas de goma.

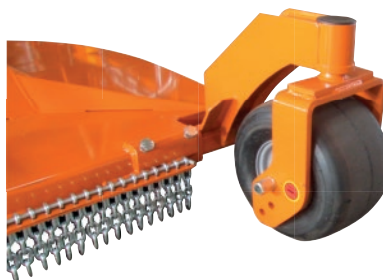

- Ruote in gomma pivotanti anteriori telescopiche (>180).
- Pivoting and telescopic pneumatic wheels front mounted (>180).
- 2 drehbare und teleskopische Gummiräder vorne (>180).
- Roues pivotantes avants et télescopiques en caoutchouc (>180).
- Ruedas delanteras en goma, pivotantes y telescópicas (>180).

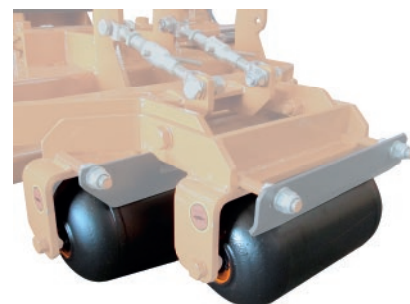

- Doppi rulli posteriori (>180).
- Twin set of rear rollers (soft terrains) (>180).
- Tandemwalze (empf. auf weiche Bodens) (>180).
- Paire de rouleaux arrière (terrains souples) (>180).
- Dobles rodillos traseras (>180).



- Ruote in gomma fisse posteriori (>180).
- Two pneumatic fixed rear wheels (>180).
- 2 fixe Gummiräder hinten (>180).
- Roues postérieures fixes en caoutchouc (>180).
- Ruedas traseras fijas de goma (>180).



- Scarico bilaterale del falciato (>160)
- Side chutes for discharge of grass (>160).
- Grasauswurfklappen (>160).
- Ailettes pour déchargement latéral (>160).
- Descarga bilateral de hierba (>160).

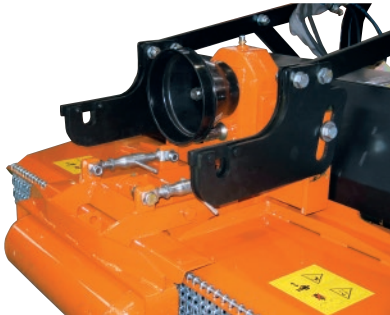

- Supporto attacco atomizzatore con riduttore e albero passante (>160).
- Support for spraying equipment mounting with gear drive output shaft (>160).
- Support für Sprüheranhängung und Getriebedurchtrieb abschaltbar (>160).
- Support pour branchement du pulvérisateur avec boîtier avec arbre de sortie arrière (>160).
- Soporte para el enganche del atomizador con eje reductor pasante(>160).



- Doppio attacco ai 3 punti con riduttore passante
- Front & Rear version, c/w through shaft in the gearbox and set of two fixed linkages.
- Front- und Heckanbau Rahmen, und Getriebe mit Durchtrieb und zweiter Dreipunktbock.
- Version avant et arrière, avec boîtier avec arbre de sortie arrière et deuxième attelage à 3 points.
- Doble enganche a los 3 puntos con reductor.



- Versione frontale.
- Front version.
- Front Version.
- Version avant.
- Versión delantera.

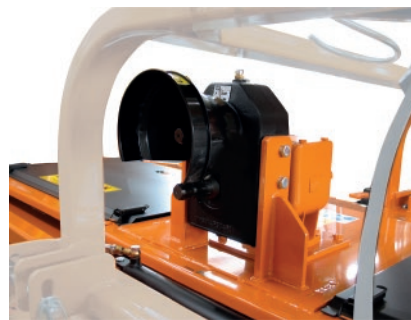

- Riduttore ad assi parallele per inversione della rotazione.
- Front & Rear version, c/w through shaft in the gearbox and set of two fixed linkages.
- Eingangsgetriebe mit zwei Eingängen für Drehrichtungsänderung.
- Boîtier avec double sortie avec rotation inverse.
- Ejes reductores paralelos para la inversión de la rotación.



- Kit diserbo con ugelli ed elettrovalvole.
- Herbicide Kit, with nozzles and electro valves.
- Herbizidanlage beidseitig, Spritzdüsen und Elektroventile.
- Jeu désherbage avec tuyères et électrovalves.
- Kit para la aplicación de herbicida..



- Albero cardanico supplementare per attacco frontale e posteriore con frizione e ruota libera (solo per doppio attacco).
- Additional PTO drive shaft for front and rear linkage with clutch and free wheel (only for double 3-points linkage).
- Zusätzliche Gelenkwelle für Heck und Frontanbau mit Kupplung und Freilauf (nur auf doppeltem Dreipunktbock).
- Arbre cardan supplémentaire pour attelage avant et arrière avec friction et roue libre (seulement pour double attelage à 3 points).



FRUTTI

OPTIONALS

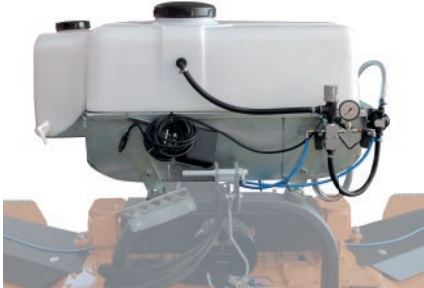

- Kit diserbo con ugelli ed elettrovalvole.
- Herbicide Kit, with nozzles and electro valves.
- Herbizidanlage beidseitig, Spritzdüsen und Elektroventile.
- Jeu désherbage avec tuyères et électrovalves.
- Kit para la aplicación de herbicida..



- Albero cardanico supplementare per attacco frontale e posteriore con ruota libera
- Additional PTO drive shaft for front and rear linkage with free wheel
- Zusätzliche Gelenkwelle für Heck und Frontanbau mit Freilauf
- Arbre cardan supplémentaire pour attelage avant et arrière avec roue libre
- Cardan para TDF delantera con rueda libre.



HANDY

OPTIONALS



- Disco interfilare girevole Ø 80 cm, con rientro a molla e protezione in gomma.
- Between-row rotating disc Ø 80 cm, by means of spring, with rubber protection.
- Drehbare Schwenkscheibe Ø 80 cm mit Federzug.
- Disque entre rangée pivotant Ø 80 cm avec ren-trée par ressort et protection en caoutchouc.
- Disco interfilas Ø 80 cm con retroceso por muelle y protección de goma.

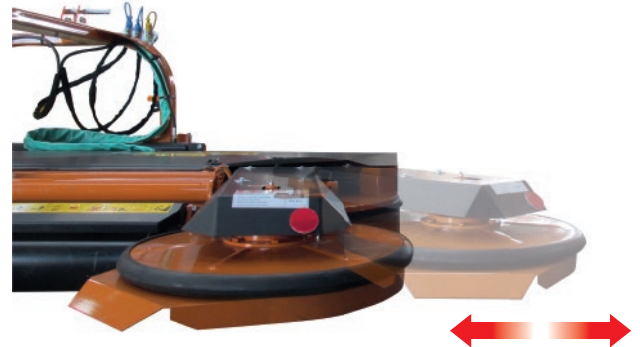

- Cilindro semplice effetto per rientro del braccio.
- Hydraulic cylinder for disc adjusting (only with mech. swing device of disc).
- E.W. Zylinder für Schwenkarmeinzug.
- Vérin hydraulique pour rappel du disque interfilare à rentrée mécanique.
- Cilindro hidráulico para retroceso del disco interfilas con retroceso mecánico.

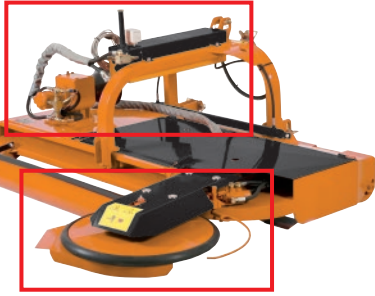

- Sistema interfilare automatico del disco a rientro idraulico, con serbatoio e pompa.
- Automatic Between-Row Swing System of disc with hydraulic swing device, c/w oil tank and pump.
- Hydr. Feintastautomatik einseitig mit hydraulischem Schwenksystem, mit Tank und Pumpe.
- Système entre rangée automatique des disques avec rentrée hydraulique, avec réservoir et pompe.
- Disco entre-hileras automático con sistema de accionamiento hidráulico con bomba y depósito de aceite.



- Regolazione maggiorata dell'altezza di taglio (4-12 cm).
- Height adjustment package roller and wheel (4-12 cm).
- Kit Walzenerhöhung vorne und hinten (4-12 cm)
- Réglage majoré de l'hauteur (4-12 cm.).
- Regulación mejorada para el ajuste de la altura de corte (4-12 cm).



- Protezione a catene anteriori.
- Front chains protector.
- Frontschutz mit Ketten.
- Protections avants avec chaînes
- Protección en cadenas delanteras

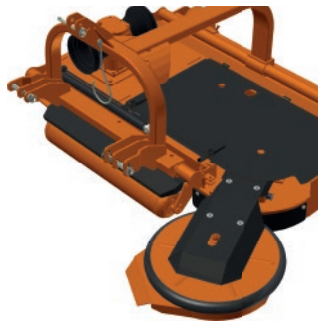

- Versione frontale.
- Front version.
- Front Version.
- Version avant.
- Versión delantera.

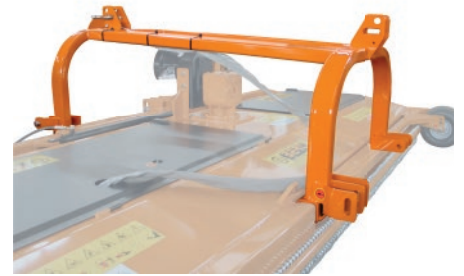

- Doppio attacco ai tre punti completo di spostamento idraulico.
- Front & Rear version, c/w hydr. side shift.
- Doppelbock Front - Heck, mit hydr. Seiteneverschiebung.
- Deuxième attelage à 3 points avec déport hydraulique.
- Doble enganche a los tres puntos con desplazamiento hidráulico.

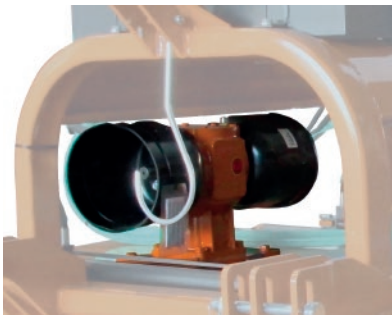

- Scatola ingranaggi con albero passante e doppia ruota libera.
- Through-shaft and double free wheel in the gearbox.
- Getriebe mit Durchtrieb und doppeltem Freilauf.
- Boîtier avec arbre de sortie arrière et double roue libre.
- Caja de transmisión con eje cardan pasante y doble rueda libre.

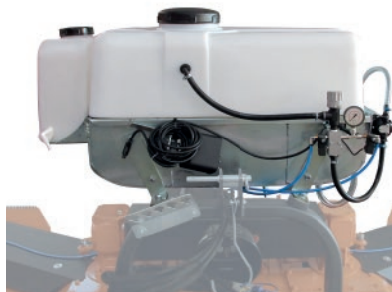

- Kit diserbo con ugelli ed elettrovalvole.
- Herbicide Kit, with nozzles and electro valves.
- Herbizidanlage beidseitig, Spritzdüsen und Elektroventile.
- Jeu désherbage avec tuyères et électrovalves.
- Kit para la aplicación de herbicida..



- Albero cardanico supplementare per attacco frontale e posteriore con ruota libera (solo per doppio attacco)
- Additional PTO drive shaft for front and rear linkage with free wheel (only for double 3-points linkage)
- Zusätzliche Gelenkwelle für Heck und Frontanbau mit Freilauf (nur auf doppeltem Dreipunktbock)
- Arbre cardan supplémentaire pour attelage avant et arrière avec roue libre (seulement pour double attelage à 3 points).
- Cardan para TDF delantera con rueda libre.



HANDY

OPTIONALS



- Ruote in gomma pivotanti anteriori (>310).
- Front pivoting pneumatic wheels (>310).
- Drehbare Gummistützräder vorne (>310).
- Roues frontales pivotantes en caoutchouc (>310).
- Ruedas pivotantes delanteras de goma (>310)



- Ruote in gomma fisse posteriori.
- Two pneumatic fixed rear wheels.
- 2 Fixe Gummiräder hinten.
- Roues postérieures fixes en caoutchouc.
- Ruedas traseras fijas de goma.



- Albero cardanico supplementare per attacco frontale e posteriore con ruota libera (solo per doppio attacco)
- Additional PTO drive shaft for front and rear linkage with free wheel (only for double 3-points linkage)
- Zusätzliche Gelenkwelle für Heck und Frontanbau mit Freilauf (nur auf doppeltem Dreipunktbock)
- Arbre cardan supplémentaire pour attelage avant et arrière avec roue libre (seulement pour double attelage à 3 points).
- Cardan para TDF delantera con rueda libre.



FLEXY - FLEXY/T

OPTIONALS



- Spostamento idraulico.
- Hydraulic side-shift.
- Hydraulische Seitenverschiebung.
- Déport hydraulique.
- Desplazamiento hidráulico.

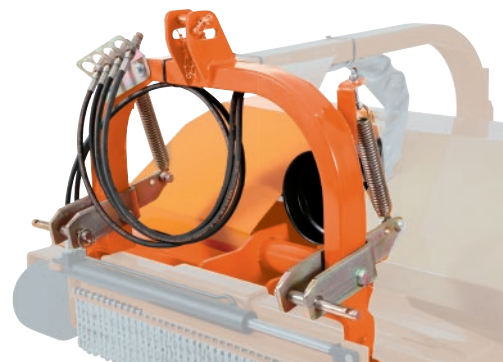

- Ammortizzatore di scarico peso, sul terzo punto (>160-230).
- Relief device for top link (>160-230).
- Entlastungsvorrichtung für Oberlenk (>160-230).
- Système de soutien du troisième point (>160-230).
- Amortiguador de descarga del peso sobre el tercer punto (>160-230).

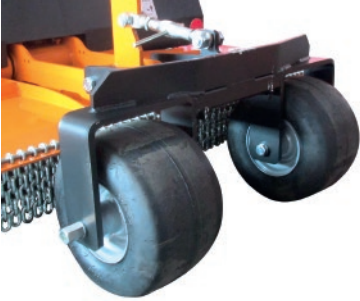

- Ruote in gomma fisse posteriori.
- Fixed rear wheels.
- 2 Fixe Gummiräder hinten.
- Roues postérieures fixes en caoutchouc.
- Ruedas traseras fijas de goma.



- Ruote in gomma pivotanti anteriori con supporto*.
 - Pivoting pneumatic wheels front mounted with support*.
 - Drehbare Gummiräder vorne mit Halterung*.
 - Roues pivotantes avants en caoutchouc avec support*.
 - Ruedas delanteras pivotantes de goma con soporte*.
- *(no 110-145 / 125-175 / 170-245)

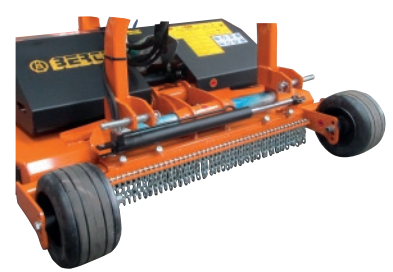

- Ruote in gomma fisse anteriori (>140-195)*.
 - Fixed wheels front mounted (>140-195)*.
 - Fixe Gummiräder vorne (>140-195)*.
 - Roues avants fixes en caoutchouc (>140-195)*.
 - Ruedas delanteras fijas de goma (>140-195).
- * (no 170-245)



- Ruote in gomma pivotanti posteriori con supporto (>160-230).
- Rear pivoting pneumatic wheels with support (>160-230).
- Drehbare Gummiräder hinten mit Halterung (>160-230).
- Roues pivotantes postérieures en caoutchouc avec support (>160-230).
- Ruedas traseras pivotantes de goma con soporte (>160-230).

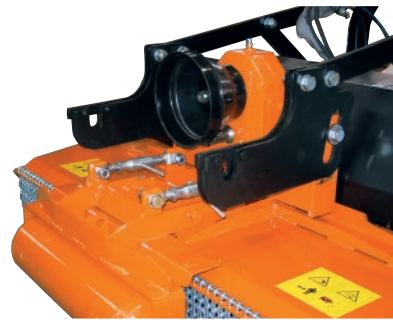

- Supporto attacco atomizzatore con riduttore passante (>140-195).
- Support for spraying equipment mounting with gear drive output shaft (>140-195).
- Support für Sprüheranhängung und Getriebedurchtrieb abschaltbar (>140-195).
- Support pour branchement du pulvérisateur avec boîtier avec arbre de sortie arrière (>140-195).
- Soporte para el enganche del atomizador con eje reductor pasante (>140-195).



- Doppio attacco ai 3 punti con riduttore passante.
- Front & Rear version, c/w through shaft in the gearbox and set of two fixed linkages.
- Front- und Heckanbau Rahmen, und Getriebe mit Durchtrieb und zweiter Dreipunktbock.
- Version avant et arrière, avec boîtier avec arbre de sortie arrière et deuxième attelage à 3 points.
- Doble enganche a los 3 puntos con reductor pasante.



FLEXY - FLEXY/T

OPTIONALS



- Versione frontale.
- Front version.
- Front Version.
- Version avant.
- Versión delantera.

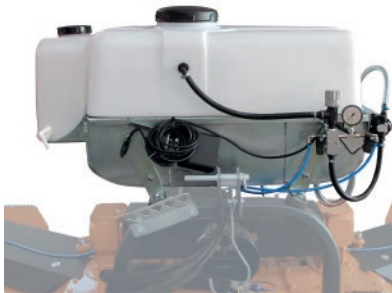

- Kit diserbo con ugelli ed elettrovalvole.
- Herbicide Kit, with nozzles and electro valves.
- Herbizidanlage beidseitig, Spritzdüsen und Elektroventile.
- Jeu désherbage avec tuyères et électrovalves.
- Kit para la aplicación de herbicida..



- Riduttore ad assi parallele per inversione della rotazione.
- Front & Rear version, c/w through shaft in the gearbox and set of two fixed linkages.
- Eingangsgetriebe mit zwei Eingängen für Drehrichtungsänderung.
- Boîtier avec double sortie avec rotation inverse.
- Ejes reductores paralelos para la inversión de la rotación.



- Albero cardanico supplementare per attacco frontale e posteriore con frizione e ruota libera (solo per doppio attacco).
- Additional PTO drive shaft for front and rear linkage with clutch and free wheel (only for double 3-points linkage).
- Zusätzliche Gelenkwelle für Heck und Frontanbau mit Kupplung und Freilauf (nur auf doppeltem Dreipunktbock).
- Arbre cardan supplémentaire pour attelage avant et arrière avec friction et roue libre (seulement pour double attelage à 3 points).
- Cardan para TDF delantera con embrague y rueda libre.



VARY/W

OPTIONALS

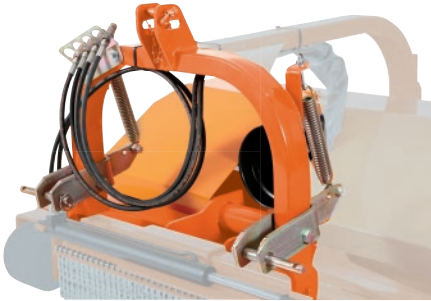

- Dispositivo scarico peso sul terzo punto (>160).
- Relief device for top link (>160)
- Entlastungsvorrichtung für Oberlenk (>160)
- Système de soutien du troisième point (>160)
- Dispositivo de descarga del peso sobre el tercer punto (>160)



- Ruote in gomma anteriori fisse.
- Two fixed wheels front mounted.
- Fixe Gummiräder vorne.
- Roues avants et fixes en caoutchouc.
- Ruedas delanteras fijas de goma.

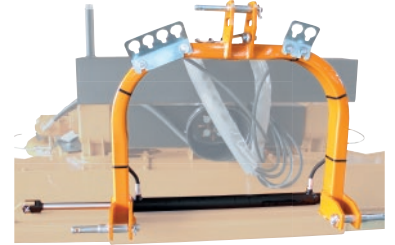

- Spostamento bilaterale idraulico.
- Hydraulic side-shift device.
- Hydraulische Seitenverschiebung.
- Déport hydraulique sur les deux côtés.
- Desplazamiento lateral hidráulico a los dos lados.

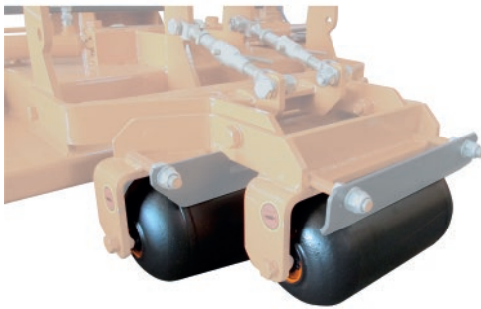

- Doppi rulli posteriori (>140).
- Twin set of rear rollers (soft terrains) (>140).
- Tandemwalze (empf. auf weiche Bodens) (>140).
- Paire de rouleaux arrière (terrains souples) (>140).
- Dobles rodillos traseras (>140).

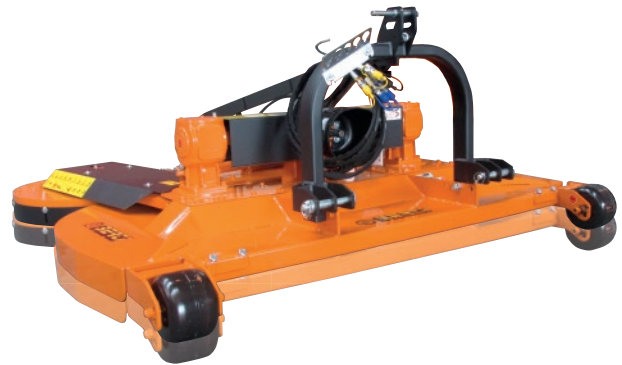

- Regolazione maggiorata dell'altezza di taglio (4-12 cm).
- Height adjustment package roller and wheel (4-12 cm).
- Kit Walzenerhöhung vorne und hinten (4-12 cm).
- Réglage majoré de l'hauteur (4-12 cm).
- Regulación mejorada para el ajuste de la altura de corte (4-12 cm).

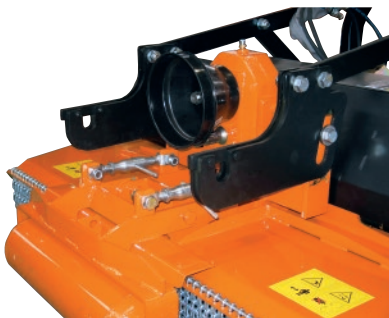

- Supporto attacco atomizzatore con riduttore passante (>140).
- Support for spraying equipment mounting with gear drive output shaft (>140).
- Support für Sprüheranhängung und Getriebedurchtrieb abschaltbar (>140).
- Support pour branchement du pulvérisateur avec boîtier avec arbre de sortie arrière (>140).
- Soporte para el enganche del atomizador con eje reductor pasante (>140).



- Versione frontale.
- Front version.
- Front Version.
- Version avant.
- Versión delantera.



VARY/W

OPTIONALS



- Riduttore ad assi parallele per inversione della rotazione.
- Front & Rear version, c/w through shaft in the gearbox and set of two fixed linkages.
- Eingangsgetriebe mit zwei Eingängen für Drehrichtungsänderung.
- Boîtier avec double sortie avec rotation inverse.
- Ejes reductores paralelos para la inversión de la rotación.



- Doppio attacco ai 3 punti con riduttore passante.
- Front & Rear version, c/w through shaft in the gearbox and set of two fixed linkages.
- Front- und Heckanbau Rahmen, und Getriebe mit Durchtrieb und zweiter Dreipunktbock.
- Version avant et arrière, avec boîtier avec arbre de sortie arrière et deuxième attelage à 3 points.
- Doble enganche a los 3 puntos con reductor pasante.

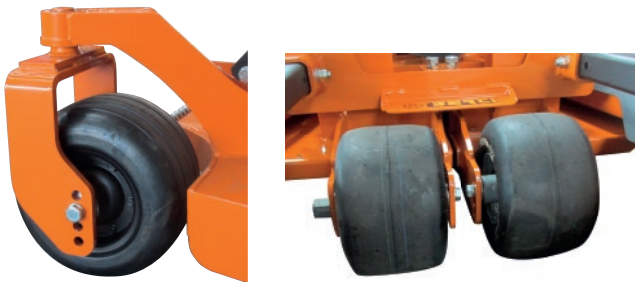

- Ruote in gomma pivotanti anteriori e fisse posteriori (>160).
- Front pivoting rubber wheels and rear fixed rubber wheels (>160).
- Drehbare Gummistützräder vorne und fixe Gummiräder hinten (>160).
- Roues pivotantes frontales et fixes postérieures en caoutchouc(>160).
- Ruedas pivotantes delanteras y traseras fijas de goma (>160).



- Scarico bilaterale del falciato, sul telaio centrale.
- Grass chutes both side, on central body.
- Grasauswurfklappen beidseitig, am haupt Rahmen.
- Ailettes pour déchargement lateral, sur le caisse central.
- Descarga lateral del triturado hacia el cuerpo central de la máquina.

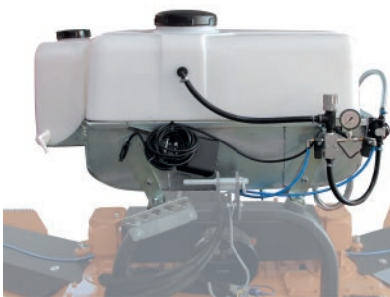

- Kit diserbo con ugelli ed elettrovalvole.
- Herbicide Kit, with nozzles and electro valves.
- Herbizidanlage beidseitig, Spritzdüsen und Elektroventile.
- Jeu désherbage avec tuyères et électrovalves.
- Kit para la aplicación de herbicida..



- Albero cardanico supplementare per attacco frontale e posteriore con frizione e ruota libera (solo per doppio attacco).
- Additional PTO drive shaft for front and rear linkage with clutch and free wheel (only for double 3-points linkage).
- Zusätzliche Gelenkwelle für Heck und Frontanbau mit Kupplung und Freilauf (nur auf doppeltem Dreipunktbock).
- Arbre cardan supplémentaire pour attelage avant et arrière avec friction et roue libre (seulement pour double attelage à 3 points).
- Cardan para TDF delantera con embrague y rueda libre.

VARY

OPTIONALS

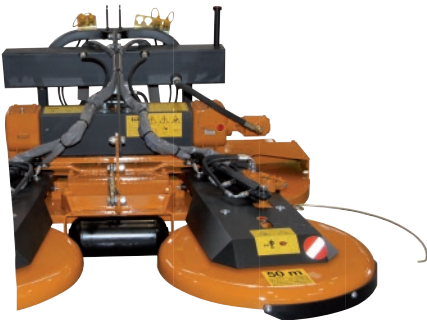
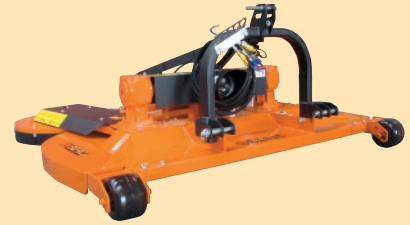

- Sistema interfilare automatico dei dischi, completo di impianto idraulico indipendente
- Automatic Between-Row Swing System of discs, c/w independent hydraulic system and flow controller.
- Hydr. Feintastautomatik beidseitig, hydr. Selbstversorgung, mit Überdrückventil.
- Système entre rangée automatique des disques, avec installation hydraulique indépendante et déviateur de flux.
- Sistema interfilar automático de los discos con instalación hidráulica independiente

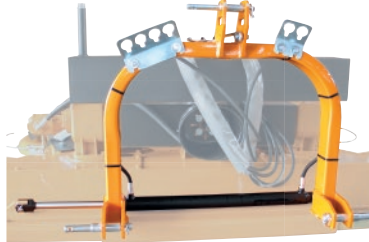

- Spostamento bilaterale idraulico.
- Hydraulic side-shift device.
- Hydraulische Seitenverschiebung.
- Déport hydraulique sur les deux côtés.
- Desplazamiento lateral hidráulico a los dos lados.

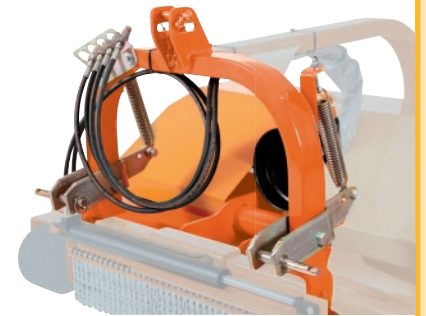

- Dispositivo scarico peso sul terzo punto.
- Relief device for top link
- Entlastungsvorrichtung für Oberlenk
- Système de soutien du troisième point
- Dispositivo de descarga del peso sobre el tercer punto.



- Ruote in gomma anteriori fisse.
- Fixed wheels front mounted.
- Fixe Gummiräder vorne.
- Roues avants et fixes en caoutchouc.
- Ruedas delanteras fijas de goma.



- Ruote in gomma pivotanti anteriori con supporto.
- Pivoting pneumatic wheels front mounted with support.
- Drehbare Gummiräder vorne mit Halterung.
- Roues pivotantes avants en caoutchouc avec support.
- Ruedas delanteras pivotantes de goma con soporte.



- Ruote in gomma posteriori, regolabile in altezza.
- Rear rubber wheels, height adjustable.
- Laufräder aus Gummi höhenverstellbar.
- Roues arrière en caoutchouc, réglable en hauteur.
- Ruedas traseras de goma regulables en altura.

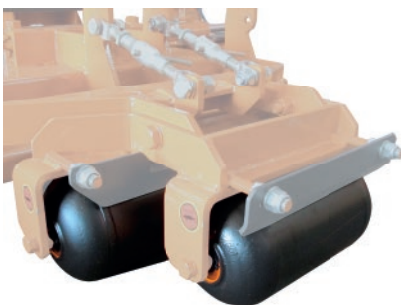

- Doppi rulli posteriori (>140).
- Twin set of rear rollers (soft terrains) (>140).
- Tandemwalze (empf. auf weiche Bodens) (>140).
- Paire de rouleaux arrière (terrains souples) (>140).
- Dobles rodillos traseras (>140).



- Regolazione maggiorata dell'altezza di taglio (4-12 cm).
- Height adjustment package roller and wheel (4-12 cm).
- Kit Walzenerhöhung vorne und hinten (4-12 cm).
- Réglage majoré de l'hauteur (4-12 cm.).
- Regulación mejorada para el ajuste de la altura de corte (4-12 cm).



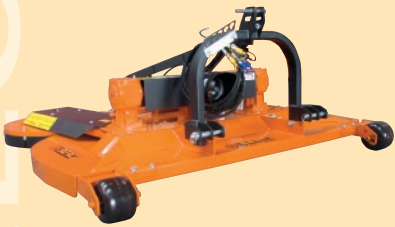

VARY

OPTIONALS



- Supporto attacco atomizzatore con riduttore passante.
- Support for spraying equipment mounting with gear drive output shaft.
- Support für Sprüheranhängung und Getriebedurchtrieb abschaltbar.
- Support pour branchement du pulvérisateur avec boîtier avec arbre de sortie arrière.
- Soporte para el enganche del atomizador con eje reductor pasante.



- Versione frontale.
- Front version.
- Front Version.
- Version avant.
- Versión delantera.

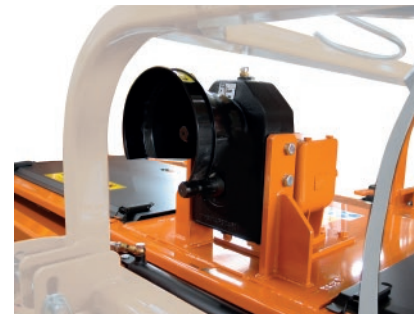

- Riduttore ad assi parallele per inversione della rotazione.
- Front & Rear version, c/w through shaft in the gearbox and set of two fixed linkages.
- Eingangsgetriebe mit zwei Eingängen für Drehrichtungsänderung.
- Boîtier avec double sortie avec rotation inverse.
- Ejes reductores paralelos para la inversión de la rotación.



- Doppio attacco ai 3 punti con riduttore passante.
- Front & Rear version, c/w through shaft in the gearbox and set of two fixed linkages.
- Front- und Heckanbau Rahmen, und Getriebe mit Durchtrieb und zweiter Dreipunktbock.
- Version avant et arrière, avec boîtier avec arbre de sortie arrière et deuxième attelage à 3 points.
- Doble enganche a los 3 puntos con reductor pasante.

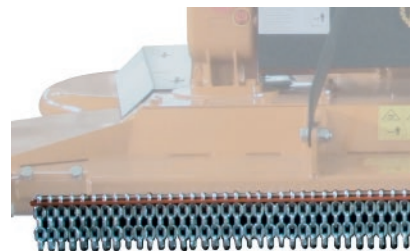

- Protezione a catene anteriori.
- Front chains protector.
- Frontschutz mit Ketten.
- Protections avants avec chaînes
- Protección en cadenas delanteras



- Scarico bilaterale del falciato, sul telaio centrale.
- Grass chutes both side, on central body.
- Grasauswurfklappen beidseitig, am haupt Rahmen.
- Ailettes pour déchargement lateral, sur le caisse central.
- Descarga lateral del triturado hacia el cuerpo central de la máquina.

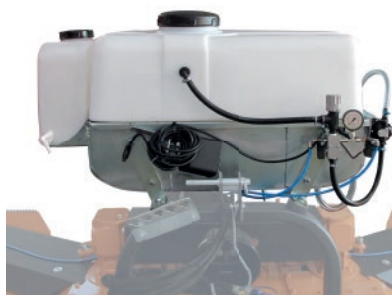

- Kit diserbo con ugelli ed elettrovalvole.
- Herbicide Kit, with nozzles and electro valves.
- Herbizidanlage beidseitig, Spritzdüsen und Elektroventile.
- Jeu désherbage avec tuyères et électrovalves.
- Kit para la aplicación de herbicida..



- Albero cardanico supplementare per attacco frontale e posteriore con frizione e ruota libera (solo per doppio attacco).
- Additional PTO drive shaft for front and rear linkage with clutch and free wheel (only for double 3-points linkage).
- Zusätzliche Gelenkwelle für Heck und Frontanbau mit Kupplung und Freilauf (nur auf doppeltem Dreipunktbock).
- Arbre cardan supplémentaire pour attelage avant et arrière avec friction et roue libre (seulement pour double attelage à 3 points).
- Cardan para TDF delantera con embrague y rueda libre.

VARY/K

OPTIONALS



- Sistema interfilare automatico dei dischi, completo di impianto idraulico indipendente
- Automatic Between-Row Swing System of discs, c/w independent hydraulic system and flow controller.
- Hydr. Feintastautomatik beidseitig, hydr. Selbstversorgung, mit Überdruckventil.
- Système entre rangée automatique des disques, avec installation hydraulique indépendante et déviateur de flux.
- Sistema interfilar automático de los discos con instalación hidráulica independiente

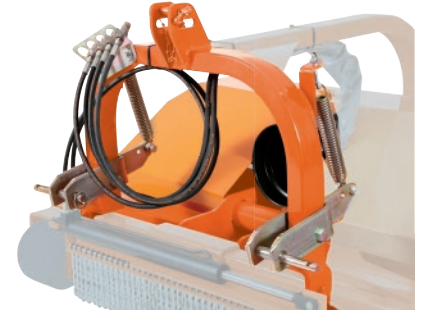

- Dispositivo scarico peso sul terzo punto.
- Relief device for top link
- Entlastungsvorrichtung für Oberlenk
- Système de soutien du troisième point
- Dispositivo de descarga del peso sobre el tercer punto.



- Versione frontale.
- Front version.
- Front Version.
- Version avant.
- Versión delantera.



- Riduttore ad assi parallele per inversione della rotazione.
- Front & Rear version, c/w through shaft in the gearbox and set of two fixed linkages.
- Eingangsgetriebe mit zwei Eingängen für Drehrichtungsänderung.
- Boîtier avec double sortie avec rotation inverse.
- Ejes reductores paralelos para la inversión de la rotación.



- Doppio attacco ai 3 punti con riduttore passante.
- Front & Rear version, c/w through shaft in the gearbox and set of two fixed linkages.
- Front- und Heckanbau Rahmen, und Getriebe mit Durchtrieb und zweiter Dreipunktbock.
- Version avant et arrière, avec boîtier avec arbre de sortie arrière et deuxième attelage à 3 points.
- Doble enganche a los 3 puntos con reductor pasante.

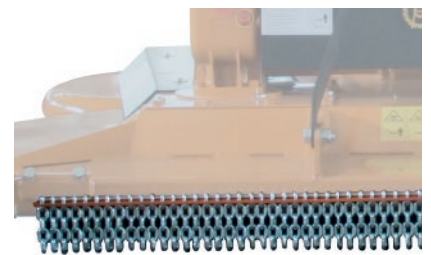

- Protezione a catene anteriori.
- Front chains protector.
- Frontschutz mit Ketten.
- Protections avants avec chaînes
- Protección en cadenas delanteras



VARY/K

OPTIONALS



- Scarico bilaterale del falciato, sul telaio centrale.
- Grass chutes both side, on central body.
- Grasauswurfklappen beidseitig, am haupt Rahmen.
- Ailettes pour déchargement lateral, sur le caisse central.
- Descarga lateral del triturado hacia el cuerpo central de la máquina.

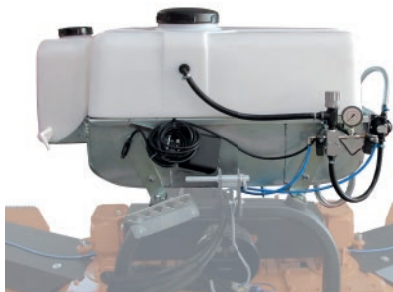

- Kit diserbo con ugelli ed elettrovalvole.
- Herbicide Kit, with nozzles and electro valves.
- Herbizidanlage beidseitig, Spritzdüsen und Elektroventile.
- Jeu désherbage avec tuyères et électrovalves.
- Kit para la aplicación de herbicida..



- Albero cardanico supplementare per attacco frontale e posteriore con frizione e ruota libera (solo per doppio attacco).
- Additional PTO drive shaft for front and rear linkage with clutch and free wheel (only for double 3-points linkage).
- Zusätzliche Gelenkwelle für Heck und Frontanbau mit Kupplung und Freilauf (nur auf doppeltem Dreipunktbock).
- Arbre cardan supplémentaire pour attelage avant et arrière avec friction et roue libre (seulement pour double attelage à 3 points).
- Cardan para TDF delantera con embrague y rueda libre.





www.bertima.it



BMP - BML

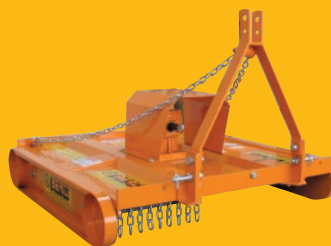

BMG



STAR



FRUTTI



HANDY



FLEXY



FLEXY/T



VARY/W

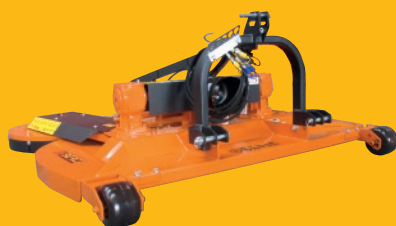

VARY



VARY/K

Le illustrazioni e i dati del presente catalogo sono indicative e non vincolanti per il costruttore • All pictures and data above are indicative only and not binding for the manufacturer • Alle in diesem Katalog enthaltenen Angaben und Zeichnungen sind annahmend und unverbindlich • Toutes les données insérées dans ce catalogue ont été indiquées seulement à titre de renseignement • Las fotografías y los datos mostrados son meramente indicativos y podrían ser variados sin previo aviso por el fabricante.



BERTI
MACCHINE AGRICOLE



Via Musi, 1/A-3 - 37042 Caldiero (VR) ITALY
Tel. +39.045.6139711 - Fax +39.045.6150251
info@bertima.it



MADE IN ITALY